

OPEN DRIVE SCREW COMPRESSORS

ATS Series

50Hz

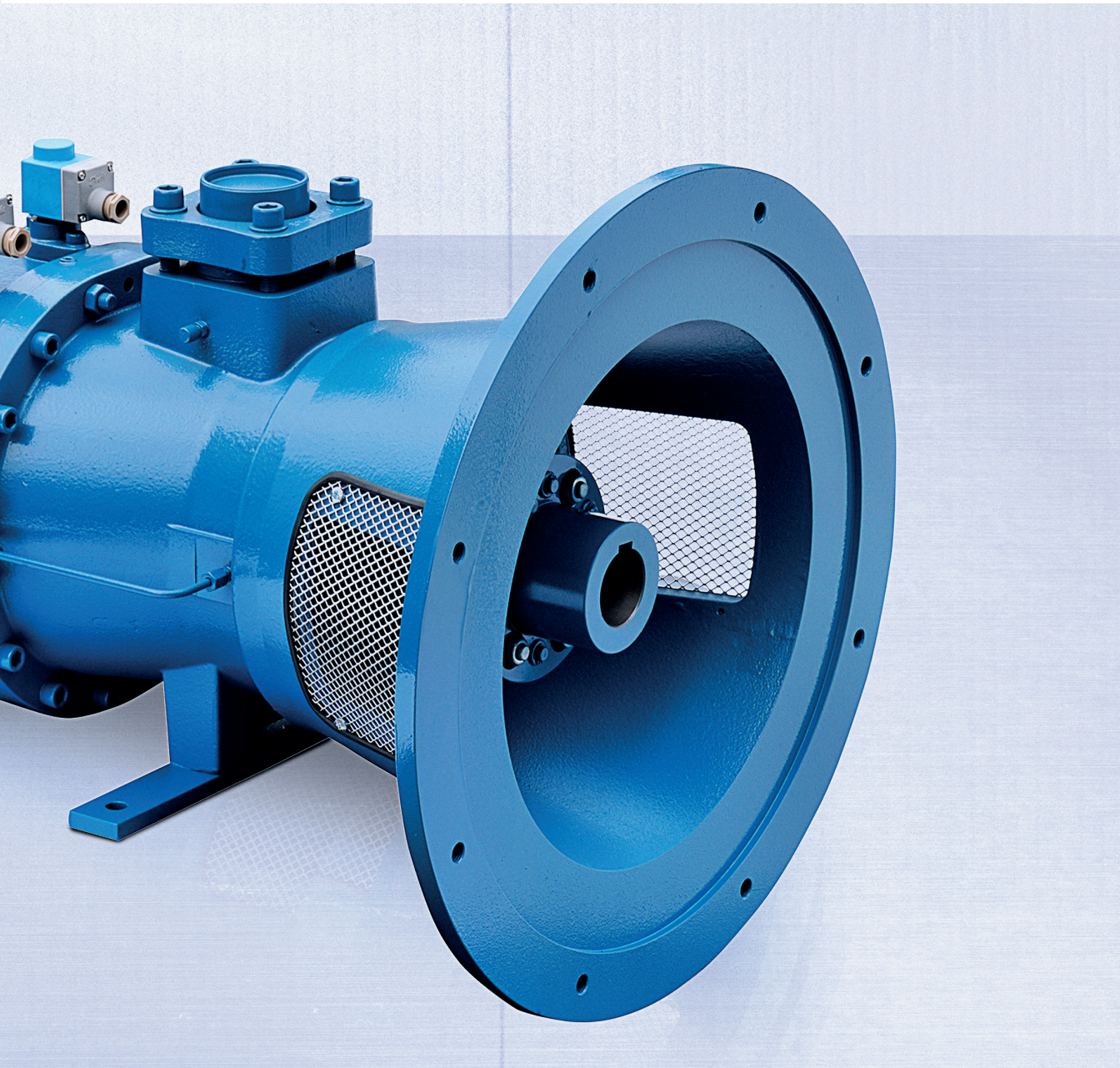

frascold[®]
BLUE IS BETTER

INDEX

4	About the Company
5	Segments and Solutions
6	Product information
14	Technical Data & Operating Limits
18	Technical Drawings and Dimensions
28	Contact us

ABOUT THE COMPANY

Frascold manufactures over 70,000 screw and reciprocating compressors a year. Our 53,000 m² factory outside of Milan (Italy) houses our advanced engineering, manufacturing and testing facilities. More than 200 employees work in the Headquarters and in the Subsidiaries based in the United States, China and India, with distribution partners and service centers in 86 countries.

4

53.000 sqm factory outside Milan (Italy) hosting our advanced engineering manufacturing and testing facilities. ①

② **More than 200 employees** working in Italy, China, India and United States.

③ **Over 70.000 screw and reciprocating compressors** manufactured every year.

④ **Distribution partners and service centers** in **86** countries.

More than 80 years ago Frascold born as a small family owned Company developing solutions in refrigeration and conditioning industry. Today we invest more and more in people, products, technologies and services aiming to become the best partner for our Customers and the touchstone for the market.

GIUSEPPE GALLI - Frascold Executive Managing Director

SEGMENTS



COMFORT



COMMERCIAL & TRANSPORT REFRIGERATION



INDUSTRIAL REFRIGERATION



PROCESS COOLING

SOLUTIONS

Cooling capacity range @50Hz



SCREW COMPRESSORS



RECIPROCATING COMPRESSORS



CONDENSING UNITS

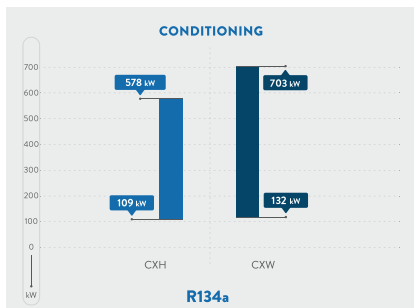

Testing Conditions Data Reference:
 CXH: Evap. T. +2°C; Cond. T. +50°C; Superheating 10K; Subcooling 5K
 CXW: Evap. T. +3°C; Cond. T. +38°C; Superheating 1K; Subcooling 5K

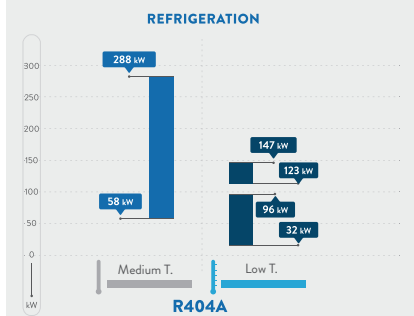

Testing Conditions Data Reference:
 Medium T.: Evap. T. -10°C; Cond. T. +45°C
 Low T.: Evap. T. -35°C; Cond. T. +40°C ECO

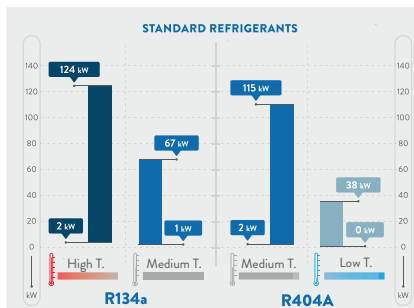

Testing Conditions Data Reference:
 High T.: Evap. T. +5°C; Cond. T. +50°C
 Medium T.: Evap. T. +10°C; Cond. T. +45°C
 Low T.: Evap. T. -35°C; Cond. T. +40°C

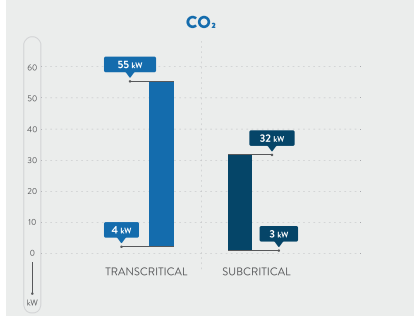

Testing Conditions Data Reference:
 Transcritical: Evap. T. -10°C; Gas cooler out T. 33°C;
 Gas cooler pressure 83,7 bar; Superheating 10K;
 Subcritical: Evap. T. -30°C; Cond. T. +10°C; Superheating 10K;

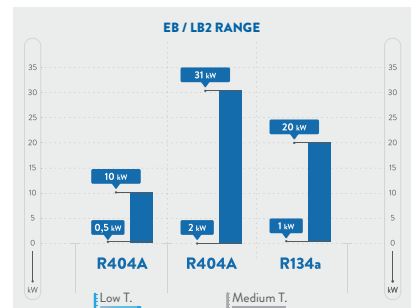

Testing Conditions Data Reference:
 Medium T.: Cooling Capacity @32°C Ambient T.; Evap. T. -10°C
 Low T.: Cooling Capacity @32°C Ambient T.; Evap. T. -35°C

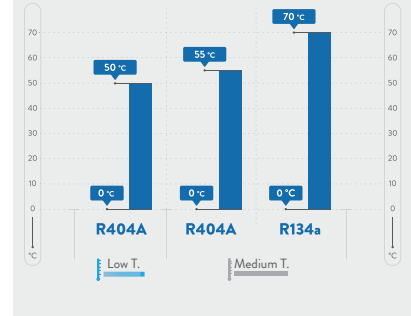

Testing Conditions Data Reference:
 Medium T.: Cooling Capacity @32°C Ambient T.; Evap. T. -10°C
 Low T.: Cooling Capacity @32°C Ambient T.; Evap. T. -35°C



OPEN DRIVE SCREW COMPRESSORS

Open drive screw compressors ATS range are designed to guarantee reliability, flexibility and efficiency. The range consists of 16 models, which offers a wide capacity range and a broad range of application including marine/industrial cooling, process cooling, heat pumps and air conditioning. These compressors have been developed specifically to work with ammonia, and are suitable to operate with hydrocarbons, traditional HFC and new low-GWP refrigerants. They guarantee a high cooling capacity with and without economizer and moreover all models are designed to work in parallel combinations with an external oil separator.

FEATURES & BENEFITS



Easy installation & Accessibility

Compact design with reduced overall dimensions and easy installation.



High Precision

Bearings with high degree of rigidity and operating precision, resistant against radial and axial load combination, compatible in operation with R717 (NH3).

Their innovative configuration protects the screws against any counter-rotations that may occur during system shut down.



Excellent performances

Profile with asymmetrical screws and optimised dimensions to guarantee high performance.



Maintenance

Mechanics designed for safe operation with long periods of minimal maintenance.



High flexibility

Universal application: R134a, R404A, R507A, R407C, R22 and R717 (NH3).
Set up for operation with economizer.



Long duration operational life

Special bearings have been designed with a cage that helps reduce noise levels and increase the load coefficient and their operating life.



Low Noise

Low noise level and no vibrations.



Coupling

Direct coupling with motor.

CONFORMITY DECLARATION

Frascold Open Drive Screw compressors for refrigeration are intended for installation in refrigeration systems. The machine or partly completed machines shall comply with local safety regulation and standards of the place of installation (within the EU according to the EU Directives 2006/42/EC Machinery Directive, 2014/68/UE Pressure Equipment, 2006/95/EC Low Voltage Directive). They may be put into operation only if the compressor has been installed in accordance with these assembly instructions.

Commissioning is only possible if the entire system into which it is integrated has been inspected and approved in accordance to the provisions of legal regulations.

The Manufacturer Declaration describes the standards to be applied.
The Manufacturer Declaration of incorporation, according to the 2006/42/EC, is available at: www.frascold.it, documentation, manufacturer's declaration.

8 PERFORMANCE DATA FSS3 SOFTWARE

Please refer to our FSS3 to check performances of all our compressors.

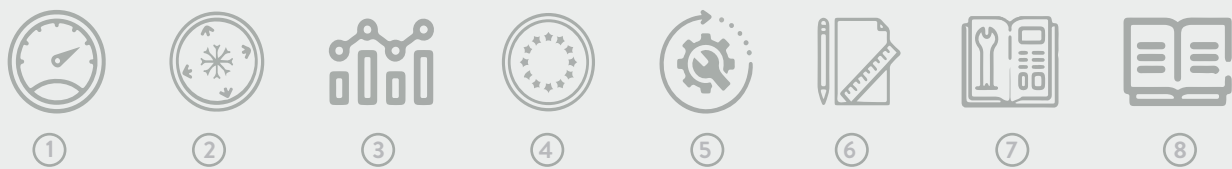

- ① Operating limits
- ② Cooling capacity
- ③ All operating data with any kind of refrigerant
- ④ European standard EN12900 at 50Hz
- ⑤ Technical information
- ⑥ Drawings
- ⑦ Manuals
- ⑧ Catalogues and certifications

CONTROL PROTECTION DEVICE

The compressor may be equipped on request with the optional Kriwan INT69FRY® Motor protector device. Compressor motor protection is based on PTC sensors that is one of the most effective and reliable protective measures against thermal overload. Due to its compact construction, the INT69 FRY is installed in the terminal boxes of the compressor. The module also performs the control of the compressor’s direction of rotation that is essential for a screw compressor.

If the temperature in one of the monitored parts reaches the nominal response temperature of the respective PTC sensor, the sensor becomes highly resistive and the motor protector switches off. After cool down, or elimination of the error, the module resets and compressor can be restarted. The relay’s switching output is a potential-free normally open contact. This circuit works in accordance with the closed-circuit principle. Only the output relay is galvanically isolated.

COOLING CAPACITY

Range @50Hz



LEGAL DISCLAIMER:
While Frascold has made every effort at the time of publication to ensure the accuracy of the information provided herein, product specifications and performances could be subject to change without notice. You can find the most updated information in our Product Selection Software FSS3 at the link: https://www.frascold.it/en/download/software/fss_3_frascold_selection_software

LUBRICATING OIL

The choice of oil depends on the properties, operating conditions, refrigerant used and the system's operating conditions. Oils different to those indicated below can be used. Special applications may require different viscosity/ oil types; for said applications contact Frascold.

Oil type	Base	Viscosity at 40°C (cSt)	Refrigerant	Application
POE 170	POE	170	R134a / R404A / R507A /R407C	Low, Medium and High Temp
MIN 46 / MIN 68	MIN	46/68	R717	Low, Medium and High Temp
PAO 68	PAO	68	R717	Low, Medium and High Temp

CAPACITY CONTROL

10

In reduced thermal load conditions, the compressor is able to bring the system being cooled to the design temperature in the shortest possible time; in this case, it is necessary to check if the increased number of compressor start-ups (resulting from a shorter cooling time) is compatible with the maximum number the compressor is able to withstand. The device used to control capacity, thus reducing the cooling capacity of the compressor, makes it possible to compensate this situation and prevent the efficiency of the entire cooling system from being compromised. Capacity control can be executed using the following operating modes:

- Models 120-150: two-step (75-100%).
- Models 186-210-240-270-300-360: three-step (50-75-100%).

Capacity control is performed by way of a solenoid valve. The control sequence of the solenoid valve and the operating diagram are shown below:

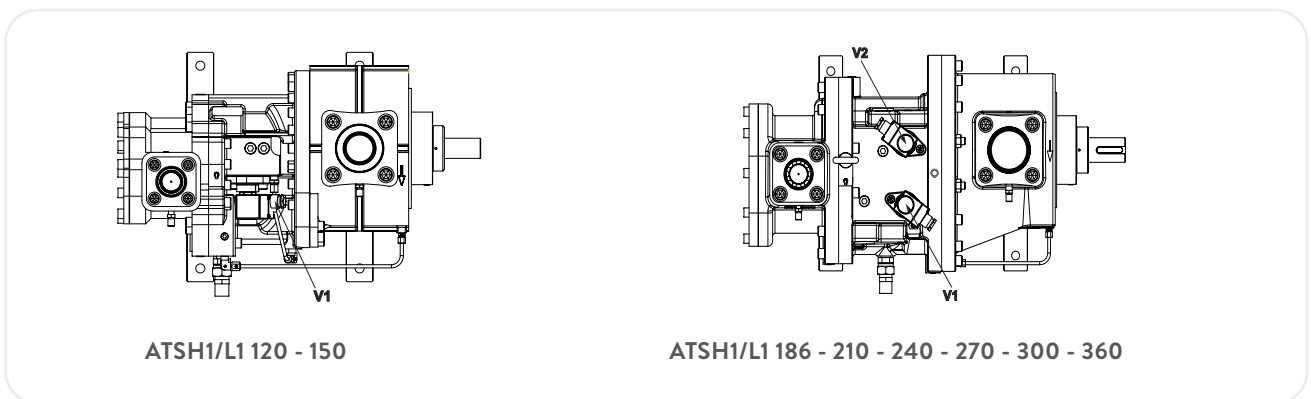

Type	At full load 100%	1. Step (75%)	1. Step (75%)
ATSH1/L1 120 - 150	V1= ●	V1= ○	
ATSH1/L1 186 - 210	V1= ●	V1= ●	V1= ○
240 - 270 - 300 - 360	V2= ●	V2=○	V2=○

PRODUCT RANGE

OPEN DRIVE SCREW MODELS RANGE

For low compression ratios
(medium-high evaporating temperature)

ATSH SERIES

ATSL SERIES

For high compression ratios
(low evaporating temperature)

MODEL DESIGNATION

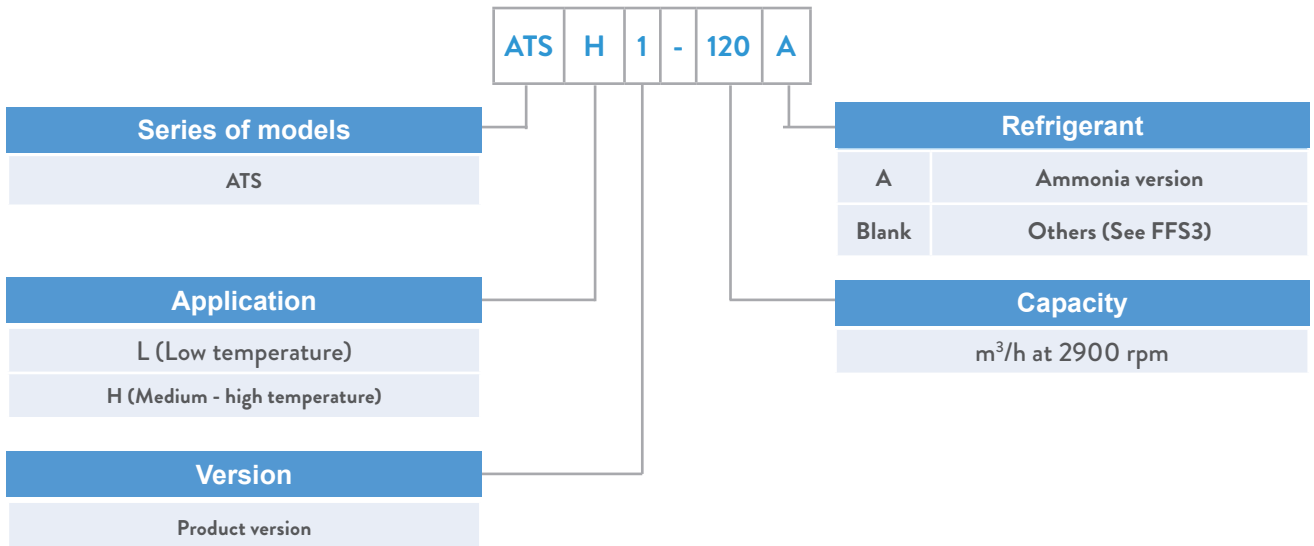

INFORMATION PLATE

All the important information to identify the compressor is displayed on the nameplate. The date of production is contained in the serial number. The user is responsible for indicating the refrigerant type.

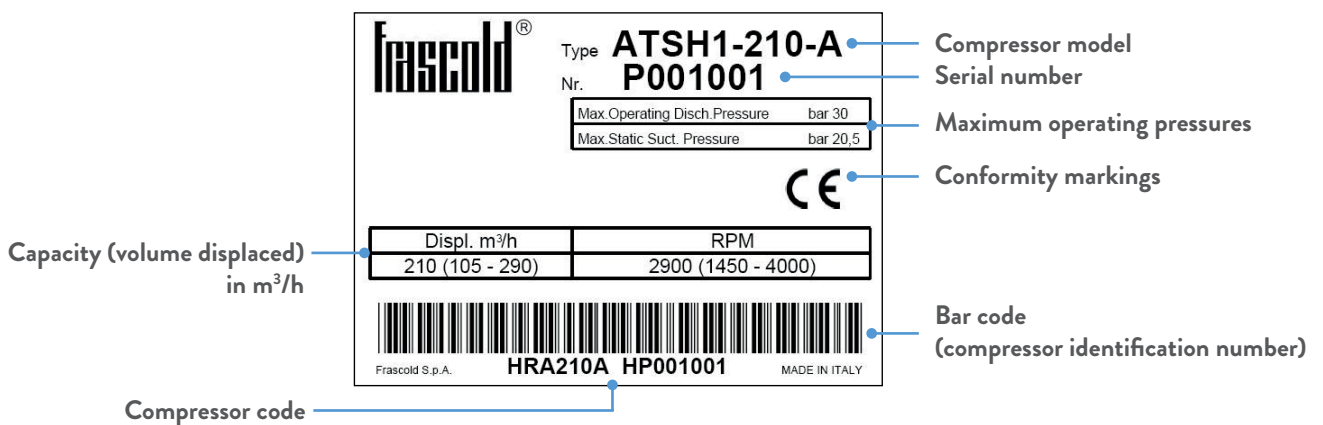

STANDARD EQUIPMENT AND OPTIONAL ACCESSORIES

OPEN DRIVE SCREW COMPRESSORS

Description	HFC		NH3	
	Std.	Opt.	Std.	Opt.
Suction and discharge bushings	•		•	
Discharge check valve	•		•	
Internal safety valve	•		•	
Capacity control	•		•	
Holding charge (nitrogen)	•		•	
Shaft coupling Joint and coupling housing for standard IEC motors B3/B5		•		•
Non-machined coupling joint and coupling housing for electric motor side		•		•
Discharge valve		•		•
Suction valve		•		•
Valve for ECO		•		•
Air cooled Oil cooler		•		n.a.
Water cooled Oil cooler		•		n.a.
Oil separator (Single stage)		•		•
Oil filter clogging pressure switch (optical or electronic)		•		n.a.
Oil injection kit		•		•
Oil shut-off valve		•		•

TECHNICAL DATA AND OPERATING LIMITS

Open Drive Screw Compressors Series

LEGAL DISCLAIMER:

While Frascold has made every effort at the time of publication to ensure the accuracy of the information provided herein, product specifications and performances could be subject to change without notice.

You can find the most updated information in our Product Selection Software FSS3 at the link:
https://www.frascold.it/en/download/software/fss_3_frascold_selection_software

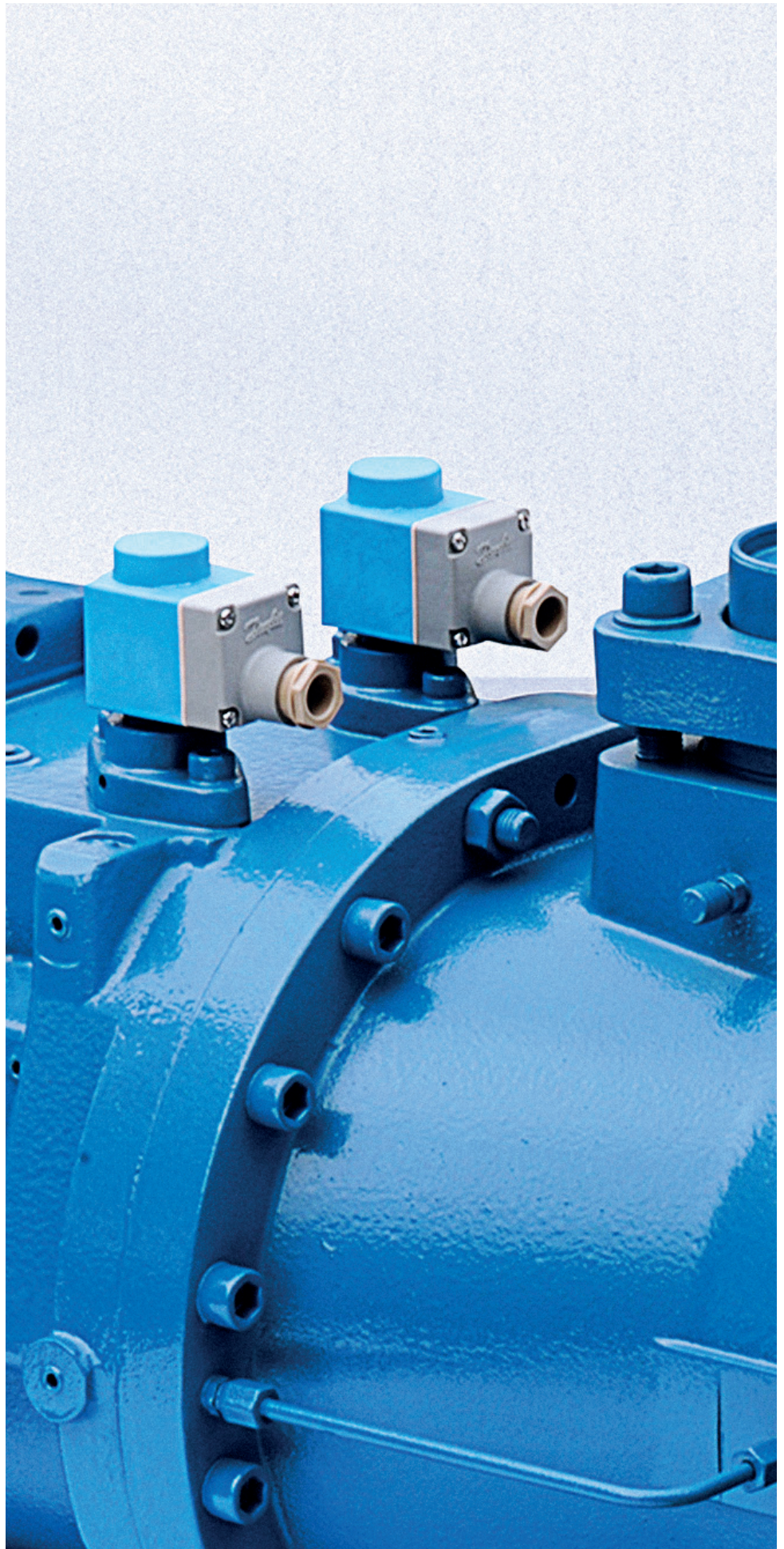

Technical data

ATSH/ATSL @50Hz

Models	Displacement		Capacity control	Speed	Line connection						Weight
	50Hz	60Hz			Suction		Discharge		Economizer		
	[m ³ /h]	[m ³ /h]			[inch]	[mm]	[inch]	[mm]	[inch]	[mm]	
ATSH1-120	120	144	(100% - 75%)	1450 - 4500	2 ½	54	1 ½ *	42	⅞	22	155
ATSL1-120	120	144	(100% - 75%)	1450 - 4500	2 ½	54	1 ½ *	42	⅞	22	155
ATSH1-150	150	180	(100% - 75%)	1450 - 4000	2 ½	54	1 ½ *	42	⅞	22	160
ATSL1-150	150	180	(100% - 75%)	1450 - 4000	2 ½	54	1 ½ *	42	⅞	22	160
ATSH1-186	186	223	(100% - 75% - 50%)	1450 - 4000	3 ½ *	80	2 ½	54	⅞	22	220
ATSL1-186	186	223	(100% - 75% - 50%)	1450 - 4000	3 ½ *	80	2 ½	54	⅞	22	220
ATSH1-210	210	252	(100% - 75% - 50%)	1450 - 4000	3 ½ *	80	2 ½	54	⅞	22	265
ATSL1-210	210	252	(100% - 75% - 50%)	1450 - 4000	3 ½ *	80	2 ½	54	⅞	22	265
ATSH1-240	240	288	(100% - 75% - 50%)	1450 - 4000	3 ½ *	80	2 ½	54	⅞	22	288
ATSL1-240	240	288	(100% - 75% - 50%)	1450 - 4000	3 ½ *	80	2 ½	54	⅞	22	280
ATSH1-270	270	324	(100% - 75% - 50%)	1450 - 4000	3 ½ *	80	2 ½	54	⅞	22	285
ATSL1-270	270	324	(100% - 75% - 50%)	1450 - 4000	3 ½ *	80	2 ½	54	⅞	22	285
ATSH1-300	300	360	(100% - 75% - 50%)	1450 - 4000	3 ½ *	80	2 ½ *	67	⅞	22	295
ATSL1-300	300	360	(100% - 75% - 50%)	1450 - 4000	3 ½ *	80	2 ½ *	67	⅞	22	295
ATSH1-360	360	432	(100% - 75% - 50%)	1450 - 4000	3 ½ *	80	2 ½ *	67	⅞	22	310
ATSL1-360	360	432	(100% - 75% - 50%)	1450 - 4000	3 ½ *	80	2 ½ *	67	⅞	22	310

* On request

Find the most updated information in our Product Selection Software FSS3 at the link :

https://www.frascold.it/en/download/software/fss_3_frascold_selection_software

Operating Limits R717 (NH3)

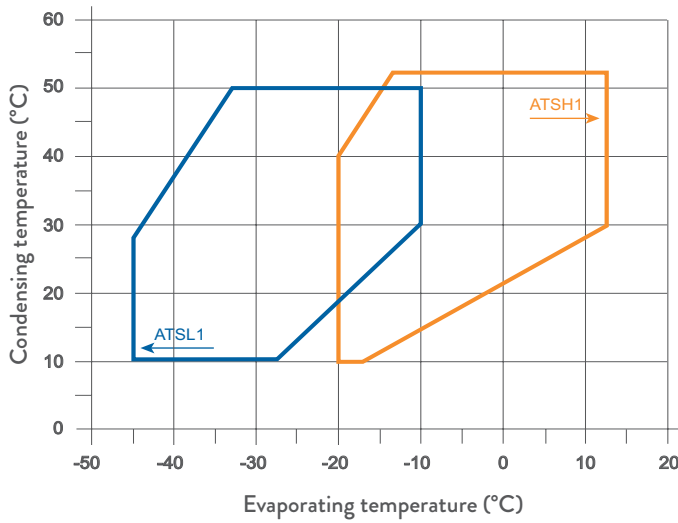

Standard application diagram

Check the envelope of each compressor model in the Frascold Selection Software program

Compressor at 100% of capacity. For operation in this zone, please contact Frascold.

R134a

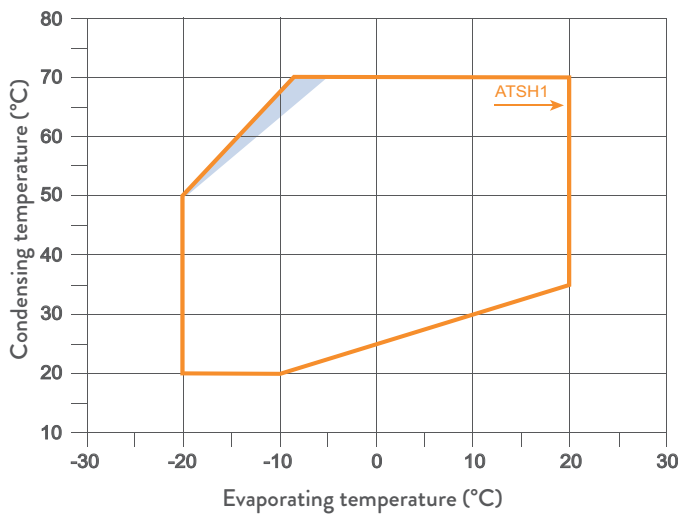

Standard application diagram

Check the envelope of each compressor model in the Frascold Selection Software program

Compressor at 100% of capacity. For operation in this zone, please contact Frascold.

R404A - R507A

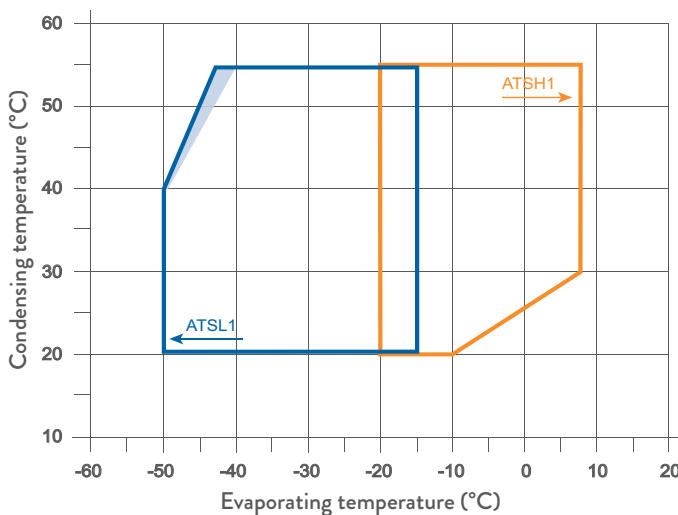

Standard application diagram

Check the envelope of each compressor model in the Frascold Selection Software program

Compressor at 100% of capacity. For operation in this zone, please contact Frascold.

TECHNICAL DRAWINGS AND DIMENSIONS

18

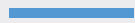

Open Drive Screw Compressors Series

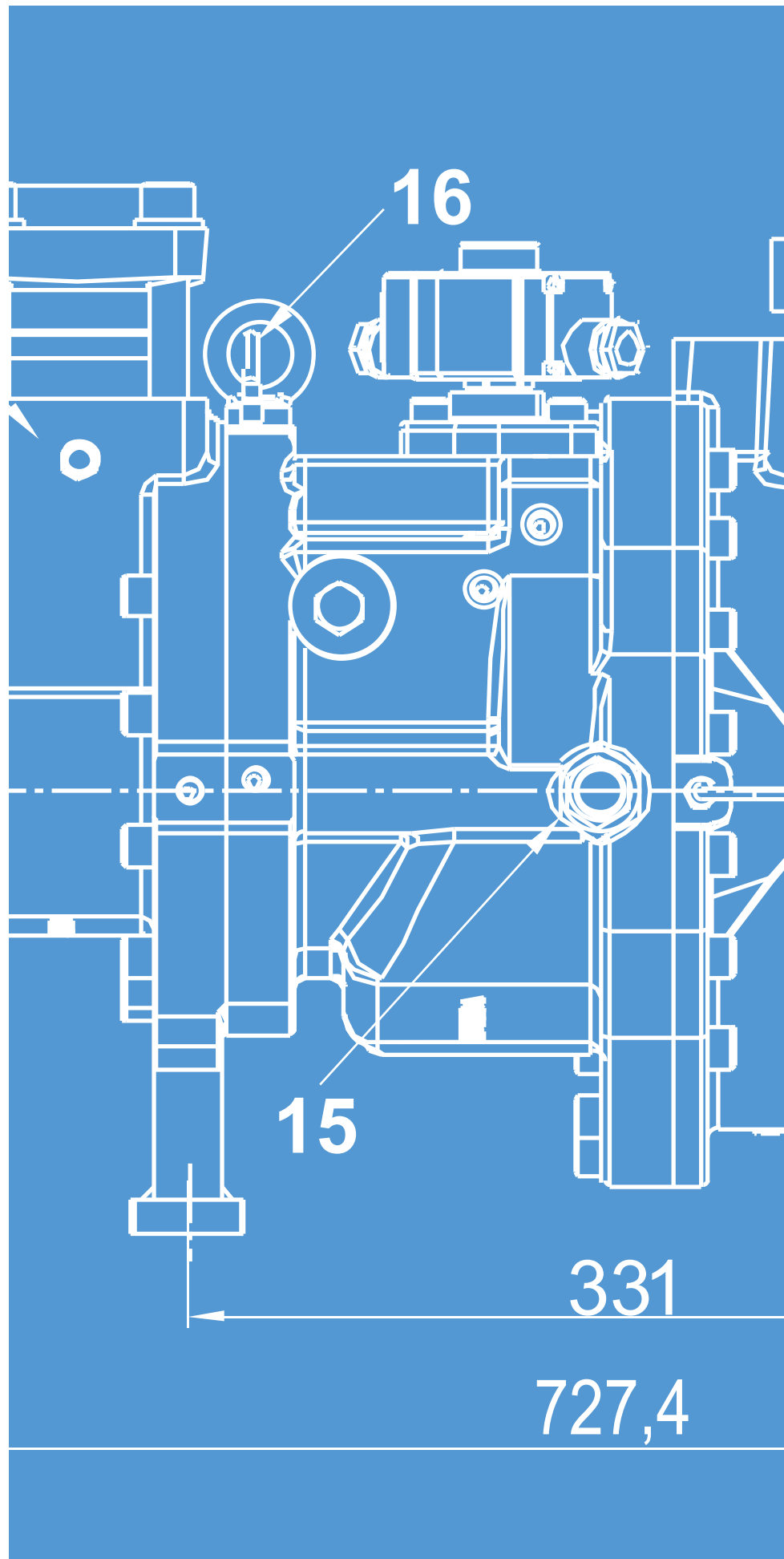

Dimensional drawing

ATSH1/L1 120 - 150

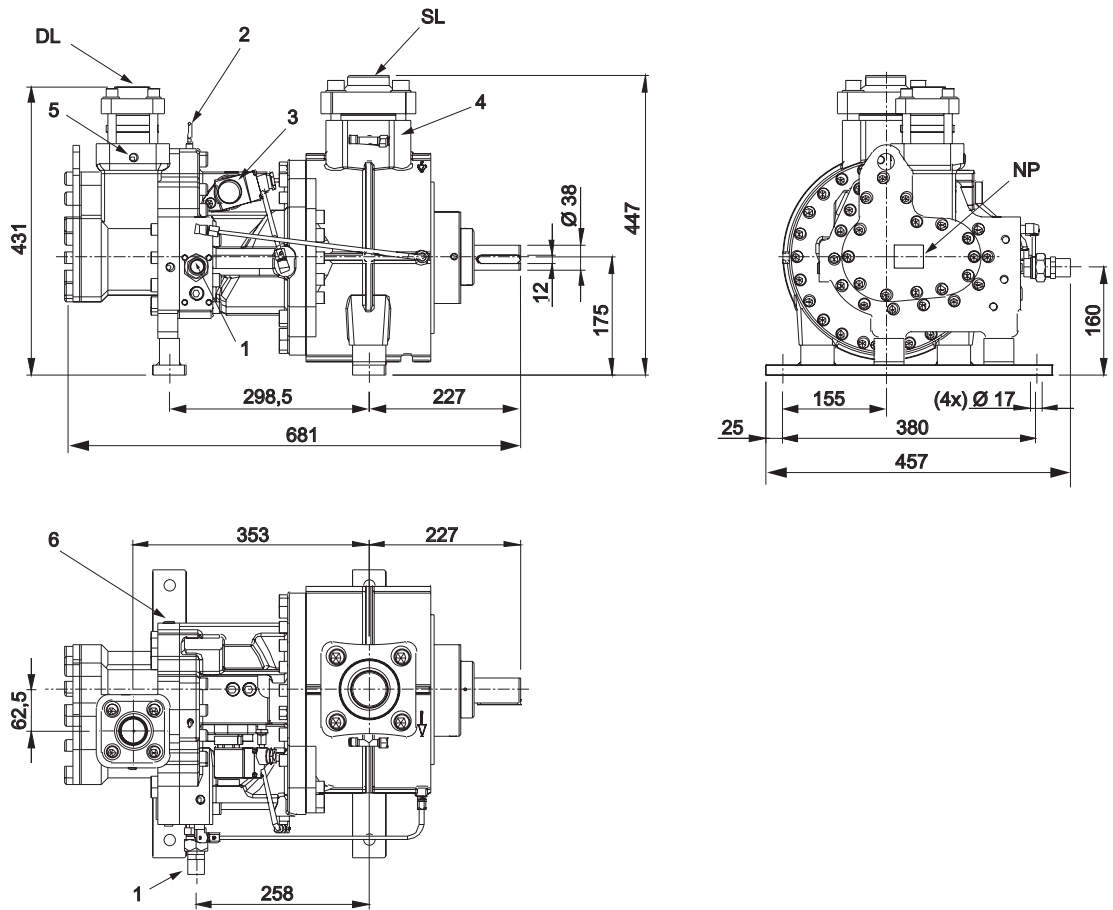

20

1	Oil return connection	
2	Discharge temperature sensor	
3	Capacity control valve	
4	Low pressure connection	
5	High pressure connection	
6	Liquid injection / economizer connection	
S	Suction valve	2 5/8" - 67 mm
D	Discharge valve	1 5/8" - 42 mm

Dimensional drawing

ATSH1/L1 186 - 210

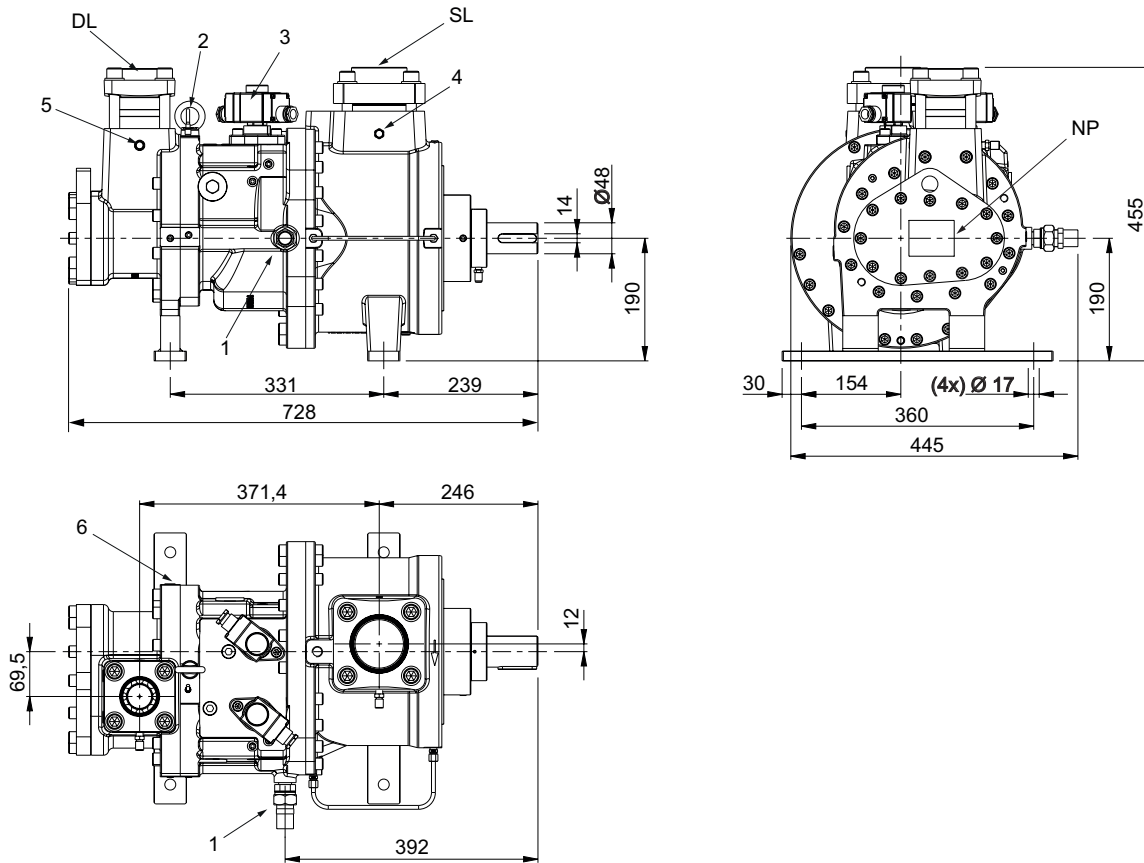

21

1	Oil return connection	
2	Discharge temperature sensor	
3	Capacity control valve	
4	Low pressure connection	
5	High pressure connection	
6	Liquid injection / economizer connection	
S	Suction valve	3 1/8" - 67 mm
D	Discharge valve	2 1/8" - 54 mm

Dimensional drawing

ATSH1/L1 240 - 270

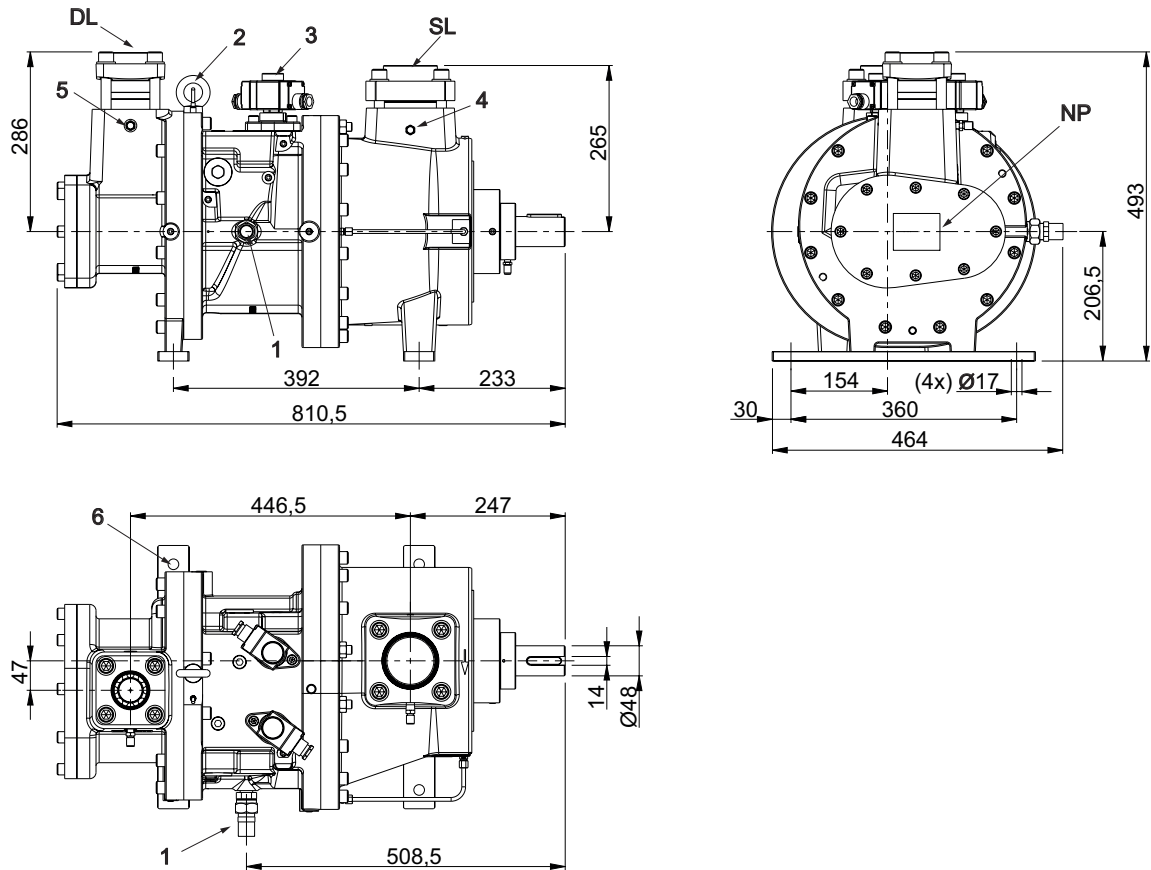

22

1	Oil return connection	
2	Discharge temperature sensor	
3	Capacity control valve	
4	Low pressure connection	
5	High pressure connection	
6	Liquid injection / economizer connection	
S	Suction valve	3 1/8" - 80 mm
D	Discharge valve	2 1/8" - 54 mm

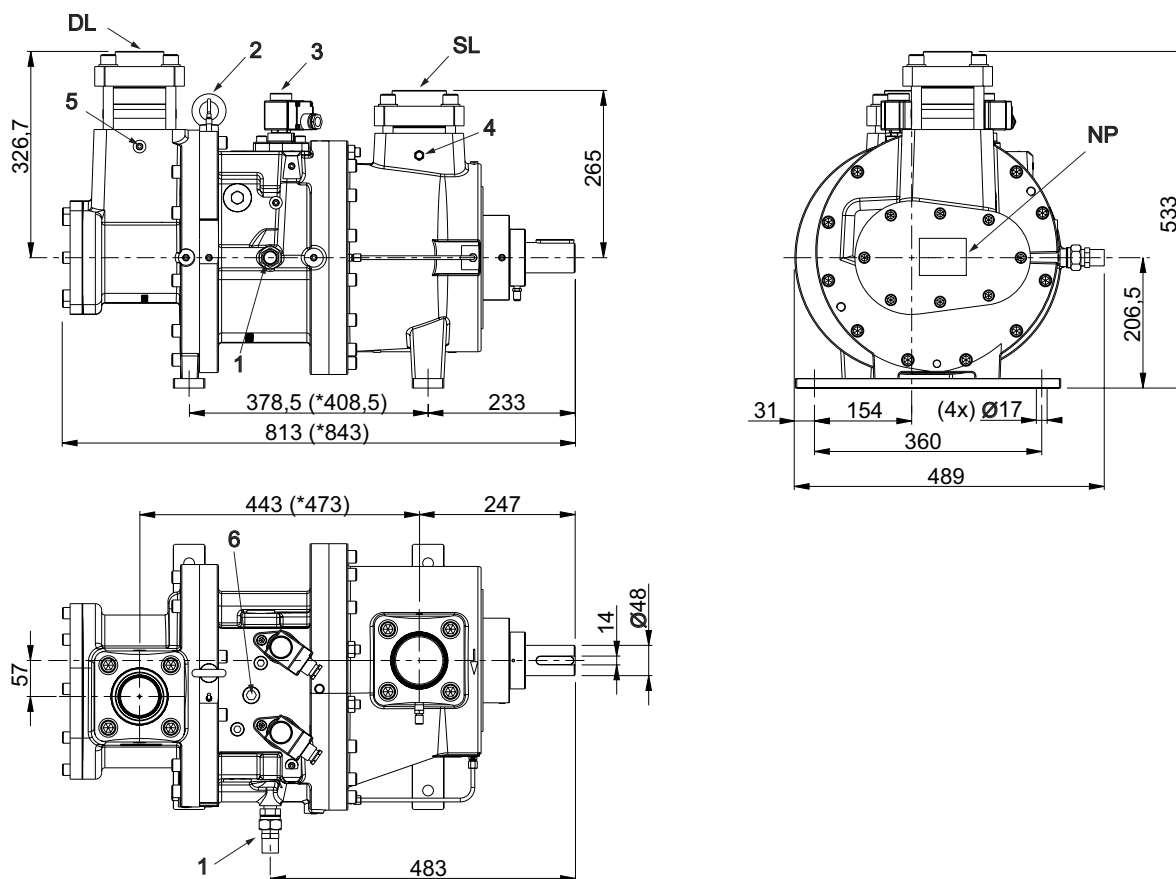

1	Oil return connection	
2	Discharge temperature sensor	
3	Capacity control valve	
4	Low pressure connection	
5	High pressure connection	
6	Liquid injection / economizer connection	
S	Suction valve	3 1/8" - 80 mm
D	Discharge valve	2 5/8" - 67 mm

Dimensional drawing

	Motor (Standard IEC B3/ B5)	Coupling weight	Coupling housing weight	Coupling housing Dimensions		Compressor and coupling housing total length
				B	A	C
	[kW]	[Kg]	[Kg]	[mm]	[mm]	[mm]
ATSH1-120 ATSL1-120	18	10	22	250	350	796
	22	10	22	250	350	796
	30	11	26	250	400	796
	37	11	26	250	400	796
ATSH1-150 ATSL1-150	30	11	26	250	400	796
	37	11	26	250	400	796
	45	11	29	250	450	796
	55	11	47	296	550	842
ATSH1/L1-240 ATSH1/L1-270	55	15	47	296	550	958
	75	15	47	296	550	958
	90	15	47	296	550	958
ATSH1/L1-300	55	15	47	296	550	960
	75	15	47	296	550	960
	90	15	47	296	550	960
	110	15	60	296	660	960
	132	15	60	296	660	960
ATSH1/L1-360	55	15	47	296	550	990
	75	15	47	296	550	990
	90	15	47	296	550	990
	110	15	60	296	660	990
	132	15	60	296	660	990

24

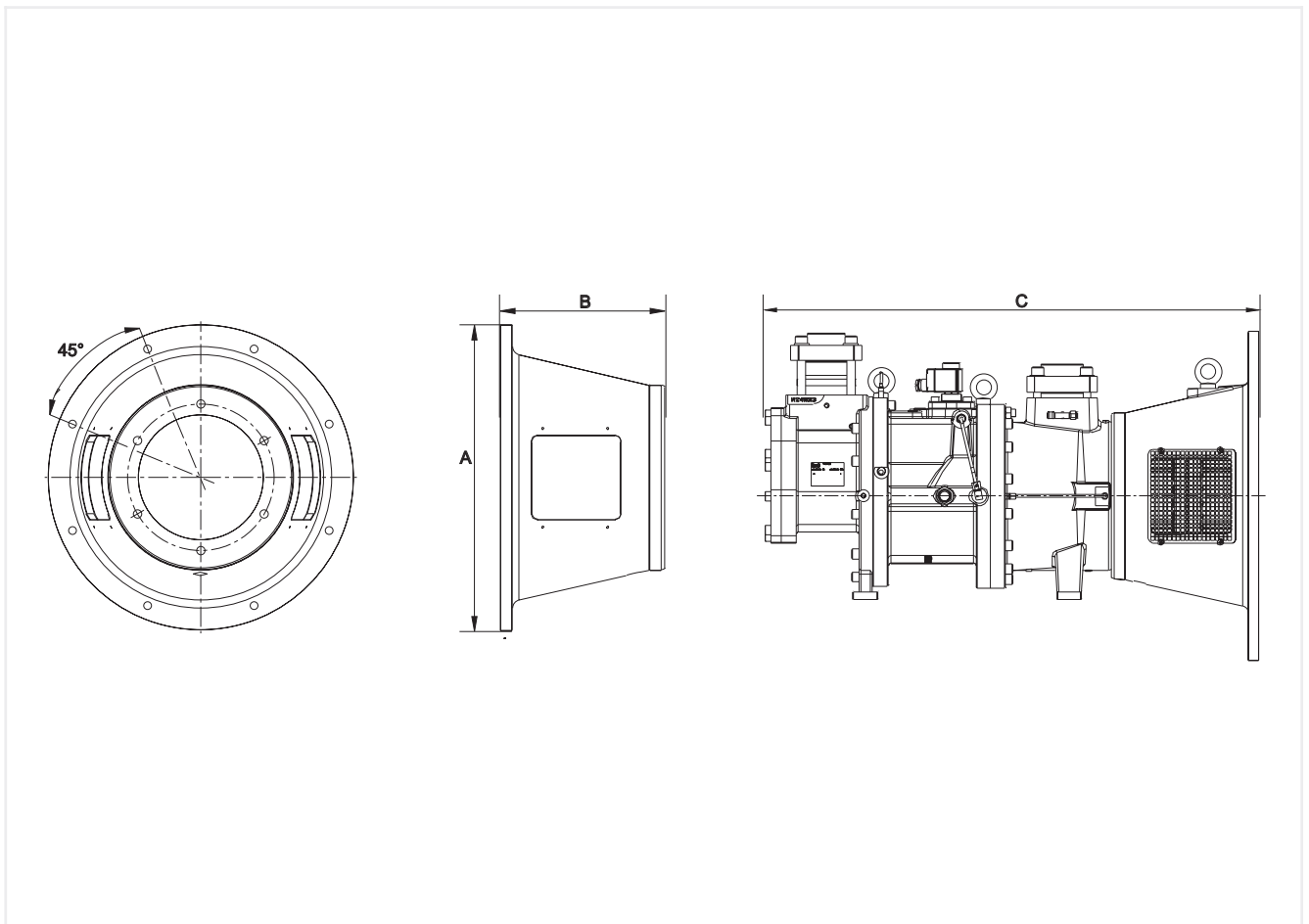

Dimensional drawing

Shaft Coupling	Compressor model							
Electric motor power 1 2 3	ATSH1-120 ATSL1-120	ATSH1-150 ATSL1-150	ATSH1-186 ATSL1-186	ATSH1-210 ATSL1-210	ATSH1-240 ATSL1-240	ATSH1-270 ATSL1-270	ATSH1-300 ATSL1-300	ATSH1-360 ATSL1-360
[kW]							4 5	4 5
18	T00WK5041156							
22	T00WK5051156							
30	T00WK5101156	T00WK5101156						
37	T00WK5101156	T00WK5101156	T00WK5201156	T00WK5201156				
45		T00WK5101156	T00WK5201156	T00WK5201156				
55		T00WK5151156	T00WK5211156	T00WK5211156	T00WK5211156	T00WK5211156	T00WK5311156	T00WK5211156
75			T00WK5221156	T00WK5221156	T00WK5221156	T00WK5221156	T00WK5411156	T00WK5221156
90			T00WK5221156	T00WK5221156	T00WK5221156	T00WK5221156	T00WK5411156	T00WK5221156
110							T00WK5411156	T00WK5411156
132							T00WK5411156	T00WK5221156

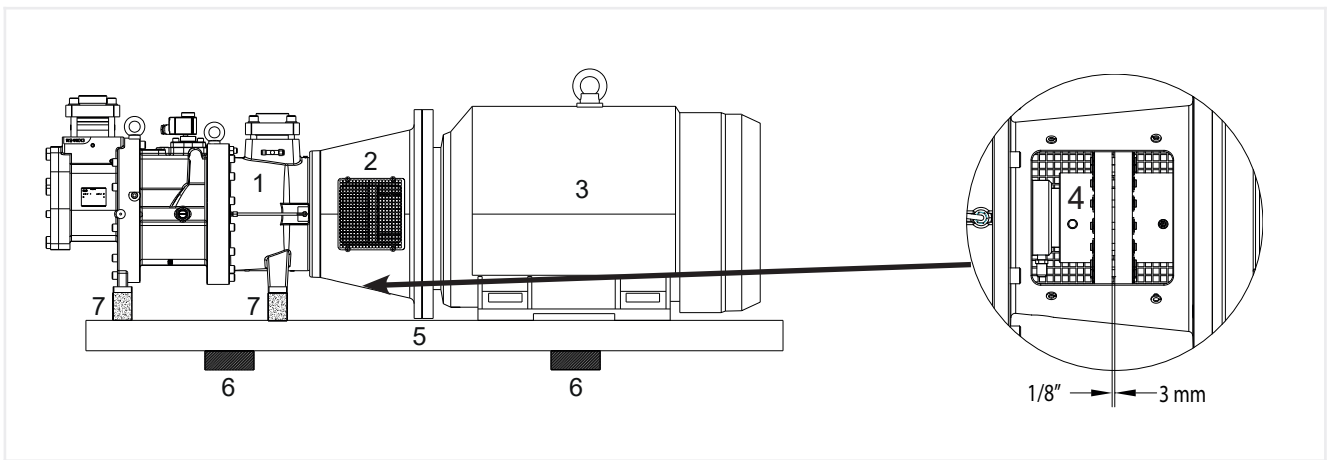

Coupling Housing	Compressor model							
Electric motor power 1 2 3	ATSH1-120 ATSL1-120	ATSH1-150 ATSL1-150	ATSH1-186 ATSL1-186	ATSH1-210 ATSL1-210	ATSH1-240 ATSL1-240	ATSH1-270 ATSL1-270	ATSH1-300 ATSL1-300	ATSH1-360 ATSL1-360
[kW]								
18	T00WK5051166							
22	T00WK5051166							
30	T00WK5101166	T00WK5101166						
37	T00WK5101166	T00WK5101166	T00WK5191166	T00WK5191166				
45		T00WK5151166	T00WK5201166	T00WK5201166				
55		T00WK5311166	T00WK5311166	T00WK5311166	T00WK5311166	T00WK5311166	T00WK5311166	T00WK5311166
75			T00WK5311166	T00WK5311166	T00WK5311166	T00WK5311166	T00WK5311166	T00WK5311166
90			T00WK5311166	T00WK5311166	T00WK5311166	T00WK5311166	T00WK5311166	T00WK5311166
110							T00WK5411166	T00WK5411166
132							T00WK5411166	T00WK5411166

- 1 Standard IEC electric motor not supplied by Frascold
- 2 For standard IEC B3/B5 IP44/IP54/IP55 electric motors
- 3 Please contact Frascold for NEMA type C and type D couplings

1	Compressor		
2	Coupling housing		
3	Electrical motor		
4	Flexible Coupling		
5	Base		
6	Anti-vibration mountings (if requested)		
7	Spacers		

OIL INJECTION KIT

The oil injection kit (optional) includes:

- Oil filter (3)
- Flow switch with electronic control module (4)
- Solenoid valve (5)
- Sight glass (6)

Not supplied for Nh3

26

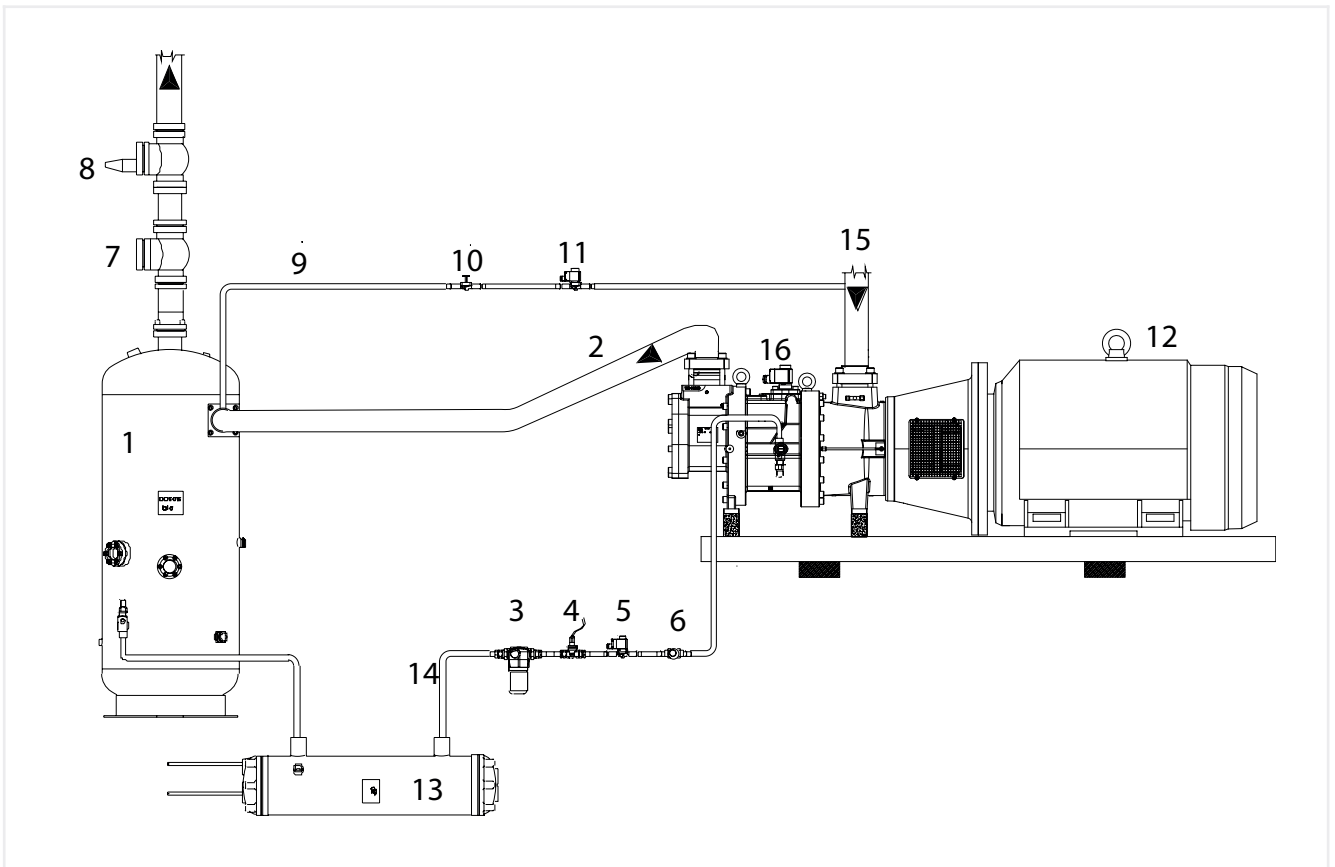

1	Remote oil separator
2	Discharge line
3	Oil filter
4	Oil flow switch
5	Oil line solenoid valve
6	Sight glass
7	Check valve
8	Discharge pressure regulation valve
9	External equalization line
10	Shut-off valve
11	Solenoid valve
12	Electric motor (standard motor not supplied by Frascold)
13	Oil cooler
14	Oil return line
15	Suction Line
16	Compressor



CONTACT AND SUBSIDIARIES



mail: frascold@frascold.it

web: www.frascold.it

Frascold headquarters

Frascold SpA Via B. Melzi 105
20027 Rescaldina (MI) Italy
Tel. +39 0331 742201 - Fax +39 0331 576102
mail: frascold@frascold.it - web: www.frascold.it

Frascold China

Frascold Refrigeration Co. Ltd
Room 612, 6th Floor,
Jinqiao Life Hub, No.3611
Zhangyang Road, New Pudong
District, Shanghai, CHINA
www.frascold.net
ph. +86 021 58650192
ph. +86 021 58650180
fax +86 021 58650180
frascold.china@frascold.net

Frascold India pvt ltd

C-908, Titanium Square,
Nr. Thaltej Cross Roads, S. G. Road,
Thaltej, Ahmedabad – 380 054
Gujarat, INDIA
Ph. +91 79 29704046/47/48
Fax +91 79 29704049
sales@frascoldindia.com
www.frascoldindia.com

Frascold USA

5901 23rd Drive West, Suite 101
Everett, WA 98203
(855) 547 5600 Office
info@frascoldusa.com
www.frascoldusa.com

frascold®
BLUE IS BETTER

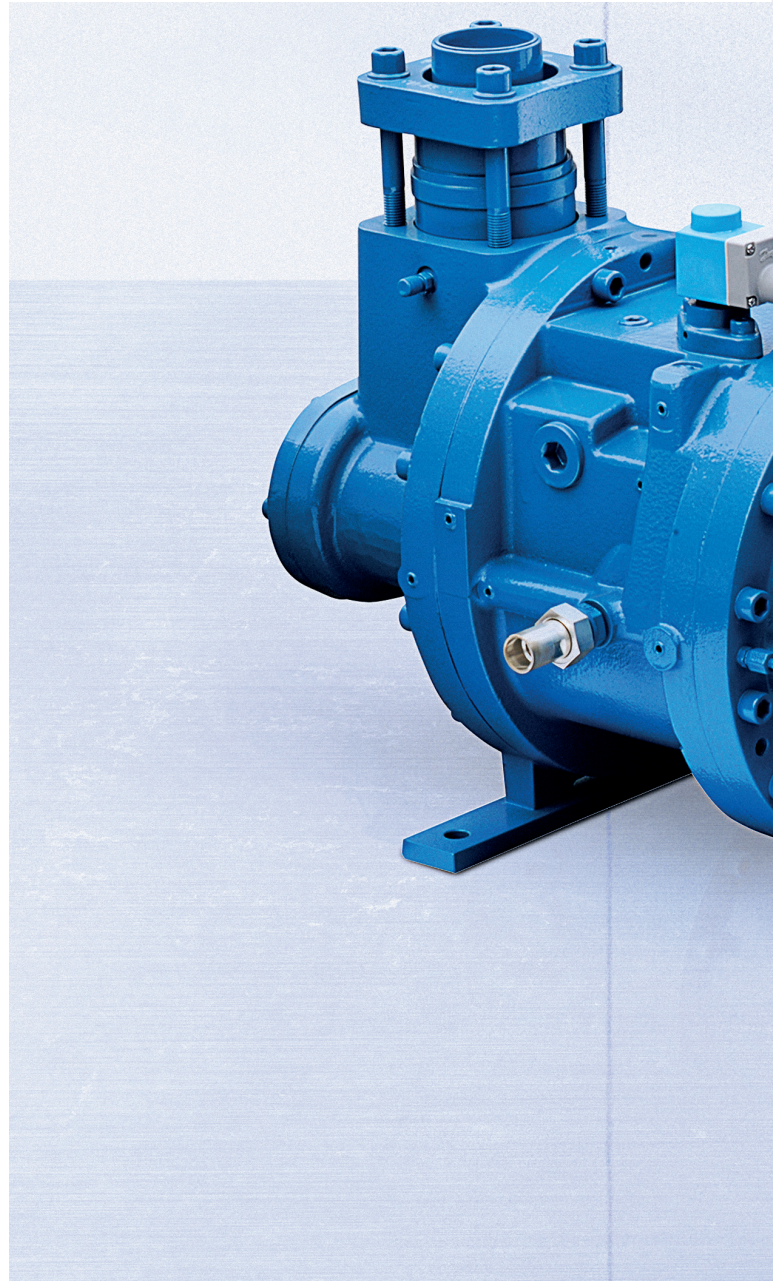

FCAT_270_00_EN